



High Performance Navigation Grade Inertial Measurement Unit **IMU-NAV-100**



The **Inertial Labs Inertial Measurement Unit (IMU-NAV)** is the latest addition to the Inertial Labs Advanced MEMS sensor-based family. Revolutionary due to its compact, self-contained strapdown, tactical grade Inertial Measurement Systems and Pitch & Roll Sensor, that measures linear accelerations, angular rates, Pitch & Roll with three-axis high-grade MEMS accelerometers and three-axis tactical grade MEMS gyroscopes. Angular rates and accelerations are determined with high accuracy for both motionless and dynamic applications.



The **Inertial Labs IMU-NAV** is a breakthrough, fully integrated inertial solution that combines the latest MEMS sensor technologies. Fully calibrated, temperature compensated, mathematically aligned to an orthogonal coordinate system, the IMU contains up to 0.5 deg/hr gyroscopes and 0.003 mg bias in-run stability accelerometers with very low noise and high reliability.

Continuous Built-in Test (BIT), configurable communications protocols, electromagnetic interference (EMI) protection, and flexible input power requirements make the **Inertial Labs IMU-NAV** easy to use in a wide range of higher order integrated system applications.

The **Inertial Labs IMU-NAV** models were designed for applications, like:

- ❖ Antenna and Line of Sight Stabilization Systems
- ❖ Passengers trains acceleration / deceleration and jerking systems
- ❖ Motion Reference Units (MRU)
- ❖ Motion Control Sensors (MCS)
- ❖ Gimbals, EOC/IR, platforms orientation and stabilization
- ❖ GPS-Aided Inertial Navigation Systems (INS)
- ❖ Attitude and Heading Reference Systems (AHRS)
- ❖ Land vehicles navigation and motion analysis
- ❖ Buoy or Racing Boat Motion Monitoring
- ❖ UAV & AUV/ROV navigation and control



IMU-NAV-100 Gyroscopes & Accelerometers Key Performance

Parameter	IMU-NAV-100 Tactical A	IMU-NAV-100 Tactical S
GYROSCOPES (± 450 deg/sec range)		
Gyroscopes Bias in-run stability	0.5 deg/hr	1 deg/hr
Gyroscopes Noise - Angular Random Walk	0.1 deg/ $\sqrt{\text{hr}}$	0.04 deg/ $\sqrt{\text{hr}}$
ACCELEROMETERS (± 8 g range)		
Accelerometers Bias in-run stability	0.003 mg	
Accelerometers Noise - Velocity Random Walk	0.008 m/sec/ $\sqrt{\text{hr}}$	
PITCH & ROLL		
Pitch & Roll static accuracy, RMS	0.03 deg	0.03 deg
Pitch & Roll dynamic accuracy, RMS	0.06 deg	0.06 deg

IMU-NAV-100 Specifications

Parameter		Units	IMU-NAV-100	
GENERAL	Output signals		Accelerations, Angular rates, Pitch, Roll, Relative Heading, Temperature, Synchronization output	
	Available in Colors		Black, White, Desert Tan or Green	
	Update rate	Hz	2000	
	Start-up time	sec	<1	
	Full Accuracy Data (Warm-up Time)	sec	<5	
Gyroscopes		Units	IMU-NAV-100 Tactical A	IMU-NAV-100 Tactical S
	Measurement range	deg/sec	±450; ±950; ±2000	±450; ±950; ±2000
	Bandwidth (-3dB)	Hz	260	260
	Data update rate	Hz	2000	2000
	Bias in-run stability (Allan Variance, RMS)	deg/hr	0.5	1
	Bias repeatability (turn-on to turn-on, RMS)	deg/hr	10	16
	Bias instability (over temperature range, RMS)	deg/hr	15	17
	SF accuracy (over temperature range)	ppm	1000	3000
	Noise. Angular Random Walk (ARW)	deg/vhr	0.1	0.04
	Non-linearity	ppm	100	200
	Axis misalignment	mrad	0.15	0.15
PERFORMANCE	Accelerometers		Units	IMU-NAV-100
		Measurement range	g	±8 / ±15 / ±40
		Bandwidth (-3dB)	Hz	260 / 260 / 260
		Data update rate	Hz	2000 / 2000 / 2000
		Bias in-run stability (RMS, Allan Variance)	mg	0.003 / 0.01 / 0.015
		Bias instability (in temperature range*, RMS)	mg	0.4 / 0.5 / 0.6
		Bias one-year repeatability	mg	0.5 / 0.7 / 0.8
		SF accuracy (over temperature range)	ppm	150 / 300 / 500
		SF one-year repeatability	ppm	500 / 1300 / 1500
		Noise. Velocity Random Walk (VRW)	m/sec/vhr	0.008 / 0.018 / 0.025
		Non-linearity	ppm	150 / 150 / 150
		Axis misalignment	mrad	0.1 / 0.1 / 0.15
	Inclinometer		Units	IMU-NAV-100
		Measurement range, Pitch / Roll	deg	±90 / ±180
		Data update rate	Hz	200
	Resolution	deg	0.01	
	Static accuracy, RMS	deg	0.03	
	Dynamic accuracy, RMS	deg	0.06	
ELECTRICAL & MECHANICAL	Environment		Units	IMU-NAV-100
		Mechanical shock (MIL-STD-810G)	g	40, 0.011 half-sine pulse
		Vibration (MIL-STD-810G)	gRMS, Hz	7, 20 – 2000
		Operating temperature	deg C	-40 to +85
		Storage temperature	deg C	-50 to +90
		Low pressure	Pa, min	1750, 30
		Humidity	%	up to 95
		MTBF (G _M @+65degC, operational)	hours	100,000
		Life time (operational)	years	10
		Life time (storage)	years	17
	Electrical		Units	IMU-NAV-100
		Supply voltage	V DC	5 to 30
		Power consumption	Watts	3 @ 5V
		Output Interface	-	RS-422/RS-232/RS-485
		Output data format	-	Binary, ASCII characters or STIM-300 output format
		EMC/EMI/ESD		MIL-STD-461G
	Physical		Units	IMU-NAV-100
		Size	mm	59.2 x 48.2 x 48.2
	Weight	grams	155	
	IMU version using customized case & connector	custom	Available	

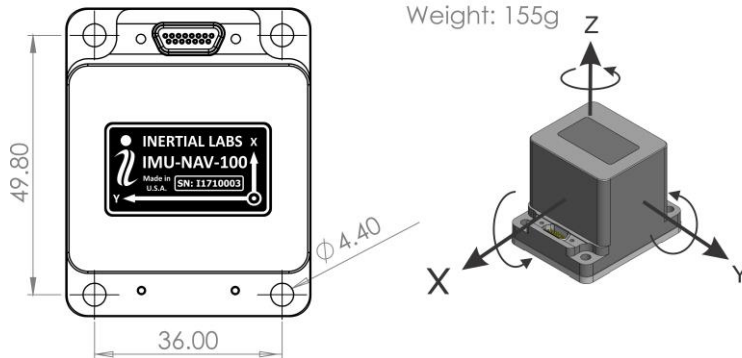
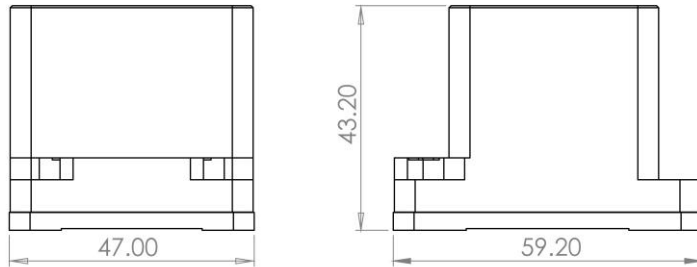
IMU-NAV-100 Mechanical interface description

Weight: 155g

Notes:

- All dimensions are in millimeters
- All dimensions within this drawing are subject to change without notice
- Customers should obtain final drawings before designing any interface hardware
- Please contact Inertial Labs, Inc. if you need IMU to be delivered in a custom enclosure/case with customized connector and output data

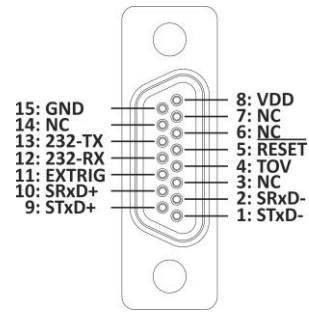
IMU-NAV-100 Electrical interface description

Pin	Name	Description
1	STxD-	RS422 inverted output
2	SRxD-	RS422 inverted input
3	NC	Do not connect
4	TOV	Time of Validity output.
5	RESET	Reset input.
6	NC	Do not connect
7	NC	Do not connect
8	VDD	Power input
9	STxD+	RS422 non-inverted output
10	SRxD+	RS422 non-inverted input
11	EXTRIG	External trigger input.
12	RS232-RX	RS232 data input
13	RS232-TX	RS232 data output
14	NC	Do not connect
15	GND	Supply and signal ground

IMU-NAV-100 Product Code Description

Model	Gyroscope	Accel	Calibration	Connector & Enclosure	Color	Version	Interface
IMU-NAV-100-A	G450	A8	TGA	C5	B	V1A._	_.1
IMU-NAV-100-S	G950 G2000	A15 A40	TGA	C5	G	V1S._	_.2
					D		_.3
					W		_.12
							_.13

Example: IMU-NAV-100-A-G450-A15-TGA-C5-B-V1A.12

Product Code Descriptions:

- IMU-NAV-100-A: Navigation Grade MEMS Inertial Measurement Unit Tactical A
- IMU-NAV-100-S: Navigation Grade MEMS Inertial Measurement Unit Tactical S
- G450: Gyroscopes measurement range = ± 450 deg/sec
- G950: Gyroscopes measurement range = ± 950 deg/sec
- G2000: Gyroscopes measurement range = ± 2000 deg/sec
- A8: Accelerometers measurement range = ± 8 g
- A15: Accelerometers measurement range = ± 15 g
- A40: Accelerometers measurement range = ± 40 g
- TGA: Gyroscopes and Accelerometers
- C5: IMU-NAV-100 Aluminum Enclosure
- B: Color – Black
- G: Color – Green
- D: Color – Desert Tan
- W: Color - White
- V1A: Guidance and Navigation
- V1S: Stabilization and Pointing
- _.1: RS-232 interface
- _.2: RS-422 interface
- _.3: RS-485 interface
- _.12: Dual RS-232 and RS-422 interface
- _.13: Dual RS-232 and RS-485 interface

Additional IMU-NAV-100 Mechanical interface description

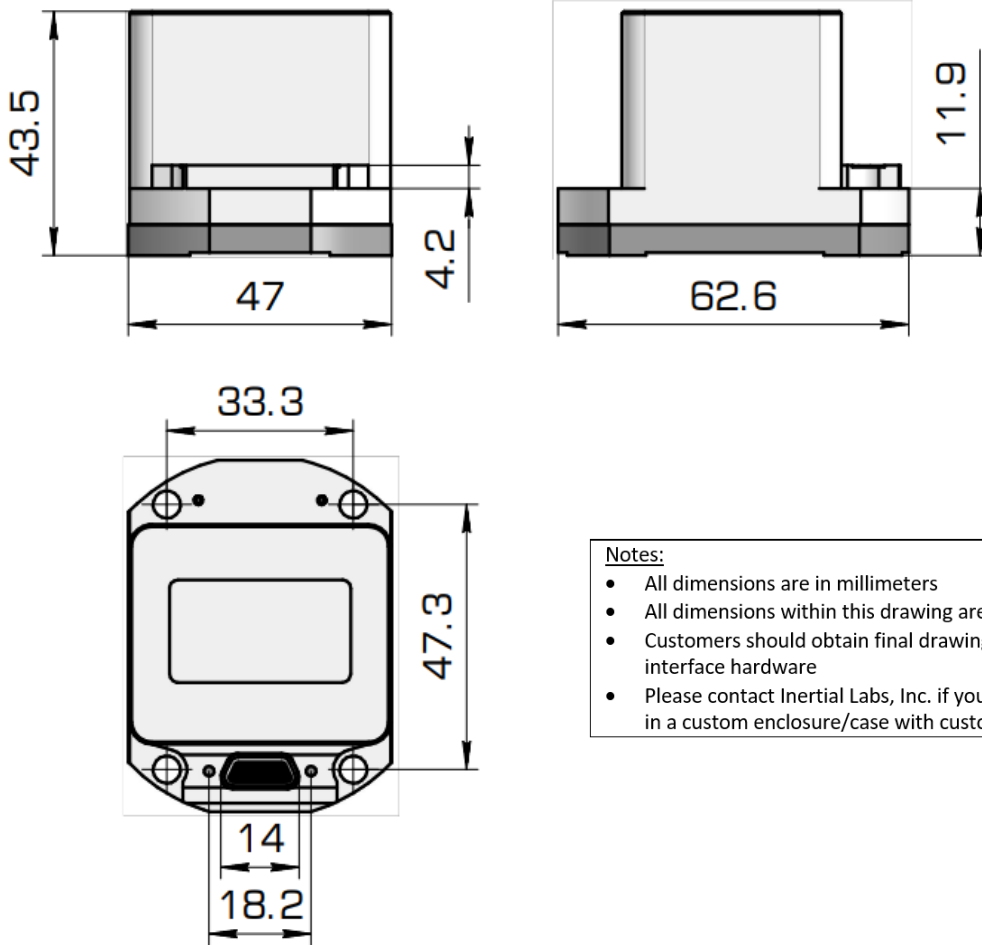

Notes:

- All dimensions are in millimeters
- All dimensions within this drawing are subject to change without notice
- Customers should obtain final drawings before designing any interface hardware
- Please contact Inertial Labs, Inc. if you need IMU to be delivered in a custom enclosure/case with customized connector and output data